

DATE : 16/06/2019



BOOKLET CODE  
13-15

# Aakash

Medical | IIT-JEE | Foundations

(Divisions of Aakash Educational Services Limited)

Regd. Office : Aakash Tower, 8, Pusa Road, New Delhi-110005. Ph.: 011-47623456

Time : 120 Min.

## Answers & Solutions

Max. Marks : 100

*for*

### NTSE (Stage-II)-2019

### SCHOLASTIC APTITUDE TEST

(For Students of Class X)

#### INSTRUCTIONS TO CANDIDATES :

Read the following instructions carefully before you open the question booklet.

1. There are 100 questions in this test. All are compulsory. The question numbers 1 to 40 belong to **Social Sciences**, 41 to 60 pertain to **Mathematics** and 61 to 100 are on **Science** subjects.
2. Please **follow the instructions** given on the OMR sheet for marking the answers.
3. Write your **eight-digit Roll Number** as allotted to you in the admission card **very** clearly on the **test-booklet** and darken the appropriate circles on the **OMR sheet** as per instructions given.
4. Write down and darken **Booklet Number** in the appropriate circles on the **OMR sheet as per instructions given**.
5. Since the time allotted for this question paper is very limited and all questions carry equal marks, you should make the best use of it by not spending too much time on any one question.
6. **Rough work** can be done **anywhere in the booklet** but not on the **OMR sheet**.
7. Every correct answer will be awarded one mark.
8. **There will be NO NEGATIVE marking.**

1. A set of guidelines called a model code of conduct is enforced during Parliamentary elections in India to avert corrupt practices. This is applied to \_\_\_\_\_.
- (1) Political parties only
  - (2) Political parties and voters
  - (3) Political parties and candidates
  - (4) Candidates contesting elections only

**Answer (3)**

2. A country has the ultimate rights and power to make decisions on internal and external matters. Also it is not dictated by any external power on its decisions relating to its relation with other country.

Which feature is reflected in these statements?

- |                 |                   |
|-----------------|-------------------|
| (1) Republic    | (2) Socialism     |
| (3) Sovereignty | (4) Authoritarian |

**Answer (3)**

3. Anti-defection law is an important feature of Indian party system. The final authority to decide on the disqualification of a member of the Parliament with respect to anti-defection lies with the \_\_\_\_\_.
- (1) President
  - (2) Prime Minister
  - (3) Chief Justice the Supreme Court of India
  - (4) Speaker of the Lok Sabha or the Chairman of the Rajya Sabha

**Answer (4)**

4. Which of the following statements exemplify the independence of judiciary in India?
- I. Judiciary is not under the control of executive and legislature.
  - II. There is less scope for interference in the working of judiciary by the political executive.
  - III. A judge of higher judiciary can be removed only through a resolution which requires 2/3rd majority of both the houses of parliament.

Choose the correct option.

- |                   |                |
|-------------------|----------------|
| (1) I and II      | (2) I and III  |
| (3) I, II and III | (4) II and III |

**Answer (3)**

5. Rajya Sabha is also called the upper house, elders house and permanent house. Which of the statement/s given below is/are true about it?
- I. Rajya Sabha has more power related to financial matters.
  - II. Rajya Sabha members continue to be in office till the next general election.
  - III. Resolution for removing the Vice-President and the President originates in Rajya Sabha.
  - IV. Number of seats allotted to a state in the Rajya Sabha is directly proportionate to its population.

- |                   |                |
|-------------------|----------------|
| (1) I, II and III | (2) III and IV |
| (3) I and IV      | (4) IV only    |

**Answer (4)**

6. In the context of Indian elections, the parties which fail to gain majority in the Parliament play the role of opposition. Consider the following statements and choose which statement/s is/are is **NOT** true.
- I. Opposition parties in India play an important role in building public opinion.
  - II. Opposition parties are not constitutionally recognized.
  - III. Opposition immediately assumes power of government, if the majority party loses its vote of confidence in the Parliament.
  - IV. Opposition parties keep a close check on the activities of the government.

- |                   |                     |
|-------------------|---------------------|
| (1) I and II only | (2) II and III only |
| (3) III only      | (4) IV only         |

**Answer (3)**

7. Consider the following statements :
- Statement I** : All countries that are democratic have written constitution.
- Statement II** : All countries that have written constitution are not necessarily democratic.
- Which of the above statement/s is/are correct?

- |                   |                      |
|-------------------|----------------------|
| (1) I only        | (2) II only          |
| (3) Both I and II | (4) Neither I nor II |

**Answer (2)**

8. China exports a toy to India at ₹150, whereas the same toy is manufactured and available in India for ₹250. When China continues to export this toy to India, this trade practice is known as \_\_\_\_.
- (1) Dumping
  - (2) Export promotion
  - (3) Import substitution
  - (4) Export subsidisation

**Answer (1)**

9. Shruti and Gautami were discussing about India's GDP and Kerala's SDP. Some of the observations made were :
- I. Kerala's per capita SDP is India's GDP divided by Kerala's population in a particular year.
  - II. Since Kerala has best literacy rate and excellent quality of life indices, it must have the highest SDP.
  - III. In a federal structure if we know all the SDPs we can have a fair idea of how big India's GDP will be in that year.
  - IV. Kerala's per capita SDP in a particular year is the value of all final goods and services produced by the Kerala state in that year divided by Kerala's population in that year.

Which of the above statements are correct?

- (1) I and III
- (2) II and III
- (3) III and IV
- (4) I, III and IV

**Answer (3)**

10. Shehnaaz joined a coaching institute for a professional course. At the time of joining the course, she paid a lump sum fee for the entire course of two years. However, she did not find the quality of teaching satisfactory and decided to quit after one year. When she asked for a refund of the fee for one year, she was refused. Which of the following right/s of Shehnaaz was/were violated?
- I. Right to choose
  - II. Right to represent
  - III. Right to be informed
  - IV. Right to seek redressal
- (1) Only I
  - (2) I and IV
  - (3) III and IV
  - (4) Only IV

**Answer (4)**

11. Which of the following reflects situation where a person is employed but do not contribute in adding to the total product?
- I. Open unemployment
  - II. Disguised unemployment
  - III. Seasonal unemployment
  - IV. Frictional unemployment
- (1) I and II
  - (2) Only II
  - (3) III and IV
  - (4) Only IV

**Answer (2)**

12. There are 100 households in the village of Awangkhul, of which the loan taken by 20 households are from the State Bank of India, another 20 households from their friends and relatives, 5 households from Indian Bank, 10 households from a Regional Rural Bank, 15 households from businessmen, 10 households from village headmen and 20 households from cooperative societies. Which of the following inference(s) is/are correct?
- I. Formal sources of credit are lower than the others.
  - II. Institutional sources of credit are higher than others.
  - III. Non-institutional sources of credit are higher than others.
  - IV. Informal sources of credit are slightly higher than others.
- (1) Only I
  - (2) I and II
  - (3) Only II
  - (4) III and IV

**Answer (3)**

13. Which of the following statements are true about food security?
- I. Landless people always have food insecurity.
  - II. Those who do not have enough nutritious food are food insecure.
  - III. Those who have enough food but not the requisite nutrition are food secure.
  - IV. Those who do not have enough purchasing power to buy sufficient food are food insecure.
- (1) I and III
  - (2) I and IV
  - (3) II and III
  - (4) II and IV

**Answer (2)**

14. Siddhik issues a cheque of ₹ 19,000 in favour of Hanush. What happens when the cheque is received and processed in Hanush's bank?
- There is no change in their bank accounts.
  - Both their bank balances increase by ₹ 19,000.
  - Siddhik's bank balance decreases by ₹ 19,000 and Hanush's bank balance increases by the same amount.
  - There is no change in Siddhik's bank balance although Hanush's bank balance sees an increase.

Based on the above statements which option is correct?

- Only I
- I and III
- Only III
- III and IV

Answer (3)

15. The daily wage of a person in rural area is ₹180. Arrange the following households in descending order of vulnerability to poverty.

Name of the Household	Person-days of employment	Size of the Household	Working members of the family
Ruldo	14	4	2
Mulkha	15	7	2
Fakira	10	5	4
Preeto	12	6	3

- Preeto > Mulkha > Fakira > Ruldo
- Mulkha > Preeto > Ruldo > Fakira
- Mulkha > Ruldo > Preeto > Fakira
- Ruldo > Fakira > Mulkha > Preeto

Answer (2)

16. The following graph shows the distribution of mean monthly temperature and average rainfall of a particular city during the year.

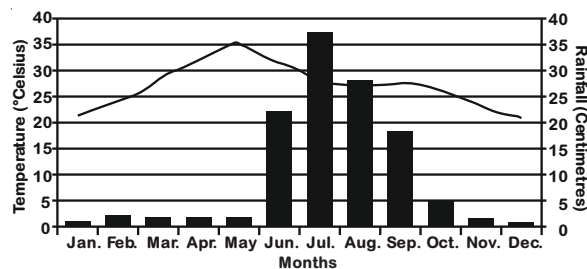

Which one of the following cities shows the climatic conditions presented in the above graph?

- Nagpur
- Chennai
- Jodhpur
- Bengaluru

Answer (4)

17. The average mean monthly temperatures of four stations are given in the following table. The temperature is influenced by the movements of land and sea breezes.

Stations	MONTHS											
	Temperature in Degree Celsius											
	JAN	FEB	MAR	APR	MAY	JUN	JUL	AUG	SEP	OCT	NOV	DEC
A	14.4	16.7	29.3	30.0	33.3	33.3	30.0	29.4	28.9	25.6	19.4	15.6
B	16.8	19.2	26.6	29.8	33.3	33.9	31.3	29.0	20.1	27.0	20.1	14.9
C	24.5	25.7	27.7	30.4	33.0	32.5	31.0	30.2	29.8	28.0	25.9	24.7
D	21.5	23.9	28.3	32.7	35.5	32.0	27.7	27.3	27.9	26.7	23.1	20.7

Which one of these stations experiences maximum moderating influence of the land and sea breezes?

- A
- B
- C
- D

Answer (3)

18. Observe the data given in the following table.

City	Female Literacy Rate (%)	Male Literacy Rate (%)	Sex-Ratio
A	66.77	85.38	960
B	71.16	82.67	980
C	73.78	77.17	989
D	59.26	79.24	972

Based on the above table, identify the city which has the extent of equality between male and female better than the rest in terms of the given parameters?

- A
- B
- C
- D

Answer (3)

19. Ruhani observes sequential change in relation to altitudinal zones and natural vegetation types dominated by *oak-chestnut*; *pine-deodar* and *silver fir-birch*.

Identify the proper sequence of vegetation type she has observed from the following.

- Alpine to Temperate to Subtropical
- Subtropical to Temperate to Alpine
- Subtropical to Alpine to Temperate
- Temperate to Alpine to Subtropical

Answer (2)

20. Observe the map given below.

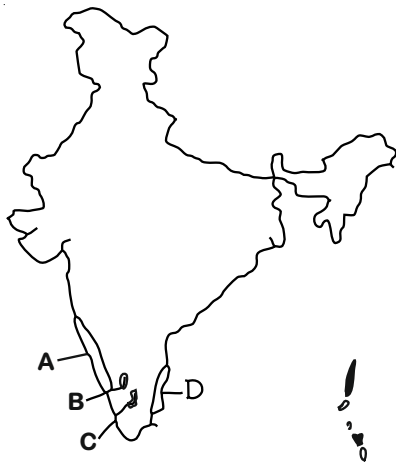

Identify the shaded regions with their corresponding geographical features and select the correct option using the codes given below.

- (1) A = Zone of laterite soil, B = Coffee producing area, C = Cotton textile industries, D = Evergreen forest cover
- (2) A = Evergreen forest cover, B = Coffee producing area, C = Zone of laterite soil, D = Cotton textile industries
- (3) A = Evergreen forest cover, B = Zone of laterite soil, C = Coffee producing area, D = Cotton textile industries
- (4) A = Cotton textile industries, B = Coffee producing area, C = Zone of laterite soil, D = Evergreen forest cover

**Answer (1)**

21. Which of the following geological sequence properly matches the tectonic events from old to recent time periods?

- (1) Formation of Aravalli - Deccan volcanism - formation of Shiwalik - upliftment of Himadri
- (2) Deccan volcanism - Formation of Aravalli - Upliftment of Himadri - formation of Shiwalik
- (3) Deccan volcanism - Formation of Shiwalik - Upliftment of Himadri - formation of Aravalli
- (4) Formation of Aravalli - Deccan volcanism - Upliftment of Himadri - formation of Shiwalik

**Answer (4)**

22. The given map shows location of different mountain peaks in India.



A mountaineer wants to scale the mountain peaks in Peninsular India starting from North to South.

Identify the correct sequence of peaks the mountaineer will follow?

- (1) A = Mahendragiri; B = Anaimudi; C = Dodabetta; D = Mahabaleshwar
- (2) A = Dodabetta; B = Mahabaleshwar; C = Mahendragiri; D = Anaimudi
- (3) A = Anaimudi; B = Mahendragiri; C = Dodabetta; D = Mahabaleshwar
- (4) A = Mahendragiri; B = Mahabaleshwar; C = Dodabetta; D = Anaimudi

**Answer (4)**

23. While teaching a topic on agriculture, geography teacher had made the following statement about a particular crop in her class. "Mean Monthly Temperature of about 27°C, high relative humidity, rainfall of 150 cm in summer months and khaddar soils are the ideal physical requirements during the period of its vegetative growth."

Which one of the following crops was stated by the teacher?

- |            |               |
|------------|---------------|
| (1) Tea    | (2) Jute      |
| (3) Rubber | (4) Sugarcane |

**Answer (2)**

24. Bibhuti was travelling to study the traditional agricultural practices among various communities in Meghalaya, Jharkhand, Odisha and Western Ghats.

Identify the correct sequence of forms of cultivation practised in these regions.

- (1) Jhumming - Kumari - Pama Dabi - Kuruwa
- (2) Kuruwa - Pama Dabi - Jhumming - Kumari
- (3) Jhumming - Kuruwa - Pama Dabi - Kumari
- (4) Pama Dabi - Kumari - Jhumming - Kuruwa

Answer (3)

25. River Indus flows through Leh and Kargil districts in the state of Jammu and Kashmir. It has four major tributaries in India. Which one of the following is the correct sequence of the tributaries arranged from East to West in terms of their confluence with river Indus?

- (1) Zaskar - Dras - Hunza - Shyok
- (2) Zaskar - Hunza - Dras - Shyok
- (3) Hunza - Dras - Zaskar - Shyok
- (4) Zaskar - Dras - Shyok - Hunza

Answer (4)

26. A tourist was travelling Indian States and came across a famous Buddhist Monastery, farming of three rice crops within the same agricultural year, a cement factory and floating gardens on a lake.

Identify the proper sequence of the States the tourist travelled.

- (1) Sikkim - West Bengal - Assam - Meghalaya
- (2) Sikkim - Arunachal Pradesh - Assam - Manipur
- (3) Arunachal Pradesh - Assam - Meghalaya - Manipur
- (4) Arunachal Pradesh - West Bengal - Manipur - Meghalaya

Answer (3)

27. Observe the following diagrams carefully.

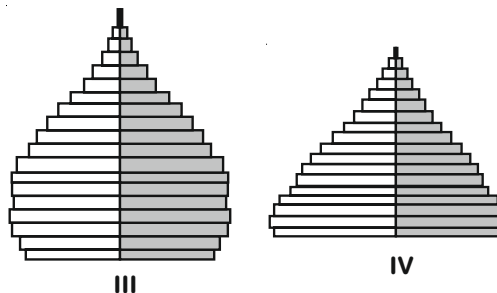
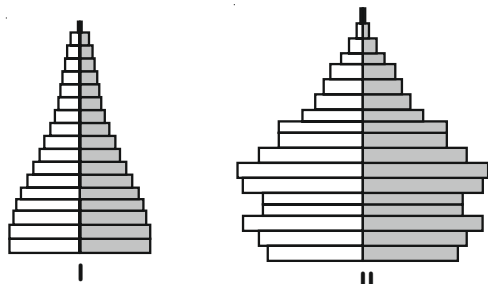

Which one of the above population pyramids is an ideal representation of India's population?

- (1) I
- (2) II
- (3) III
- (4) IV

Answer (1)

28. Which of the following statements regarding printing in Medieval Europe are correct?

- I. Wood block printing reached Europe in the 13<sup>th</sup> Century.
- II. The aristocrats and monks criticized printed books as cheap vulgarities in the beginning.
- III. Printing did not entirely displace the art of producing books by hand.
- IV. Martin Luther had reservations against printing of books.

- (1) I, II and III
- (2) I, III and IV
- (3) I, II and IV
- (4) II, III and IV

Answer (1)

29. Which of the following statements related to Mahatma Gandhi's view on Satyagraha are correct?

- I. The movement in South Africa was not passive resistance.
- II. It is the weapon of the people, who are not weak.
- III. India could not militarily face Britain.
- IV. Truth is the supreme *dharma*.

- (1) I, II and III
- (2) I, II and IV
- (3) II, III and IV
- (4) I, III and IV

Answer (1)

30. Which of the following statements relating to the 'Scorched Earth Policy' in Java are correct?

- I. The Dutch destroyed the saw mills.
- II. Teak logs were burnt by the Dutch.
- III. Trees were cut freely to meet war needs.
- IV. The villagers were encouraged to expand cultivation in the forest areas.

- (1) I and II                      (2) I, II and III  
 (3) I and IV                     (4) II, III and IV

Answer (2)

31. Which of the following statements about opium cultivation in India during the British period are correct?

- I. The peasants could sell off the produce freely.
- II. Local traders offered higher prices for opium.
- III. Opium production was increasing in territories that were not under the British.
- IV. Peasants were getting money advances from the village headman to produce opium.

- (1) I, II and III                (2) I, II and IV  
 (3) I, III and IV              (4) II, III and IV

Answer (4)

32. Observe the given picture taken from New Orleans, Illustrated London News, 1851.



What does the picture represent?

- (1) Mourning
- (2) Slave auction
- (3) Market place
- (4) Roadside gathering

Answer (2)

33. Why were Nghe An and Ha Tinh provinces called 'electrical fuses' of Vietnam?

- (1) They were near to the capital city and were centers of power.
- (2) They were among the poorest provinces and had an old radical tradition.
- (3) They were very rich and had strong trade links with the outer world.
- (4) They were at the borders and were in conflicts with the neighbouring countries.

Answer (2)

34. Which of the following would be the part of the surroundings in a *chawl* in Bombay during the colonial period?

- I. Large number of people living in shared rooms.
- II. A large population of people belonging to depressed and lower classes.
- III. Streets and neighbourhood being used for a variety of activities such as cooking, washing and sleeping.
- IV. Liquor shops and *Akharas* in any open spot.

- (1) I, II and III                (2) I, III and IV  
 (3) II and III                 (4) II, III and IV

Answer (2)

35. Which of the following statements are true in the context of Cricket in Victorian England?

- I. The rules of cricket were made to favour those who were described as "Players".
- II. The wages of professionals were paid by patronage or subscription or gate money.
- III. Cricket was viewed as a way of teaching English boys discipline, importance of hierarchy and leadership qualities.
- IV The rich who played were called amateurs.

- (1) I, II and III                (2) I, II and IV  
 (3) I, III and IV              (4) II, III and IV

Answer (4)

36. Which of the following statements are true for eighteenth century France?

- I. There was much criticism of slavery.
- II. The National Assembly feared opposition from businessmen who were dependant on slave trade.

III. Plantation owners understood their freedom as including the right to enslave Africans.

IV The Convention of 1791 legislated to free all slaves in the French overseas possessions.

- (1) I and II                      (2) I, II and IV  
(3) II and III                    (4) II, III and IV

**Answer (3)**

37. Which of the following statements are true in the context of Liberals in Modern Europe?

- I. They opposed the uncontrolled power of dynastic rulers.  
II. They wanted to safeguard the rights of individuals against governments.  
III. They argued for Independent judiciary.  
IV They believed in universal adult franchise for all men and women with property.

- (1) I, II and III                (2) I, II and IV  
(3) I, III and IV                (4) II, III and IV

**Answer (1)**

**Directions: (Questions 38 - 40)**

Read the statements and select the correct answer from the options given below.

- (1) Statement 1 is true, Statement II is false.  
(2) Statement 1 is false, Statement II is true.  
(3) Both statements are true, and Statement II provides explanation to Statement I.  
(4) Both Statements are true but Statement II does not provides explanation to Statement I.

38. **Statement I:** The Bretton Woods System came up during the post-World War Period.

**Statement II:** The industrial nations had massive growth of trade and incomes.

**Answer (4)**

39. **Statement I:** Potatoes had been discovered by the Europeans in the Americas.

**Statement II:** Poor people in Ireland were dependent on potatoes to escape starvation in the 19<sup>th</sup> century.

**Answer (2)**

40. **Statement I:** The President of India cannot claim the kind of direct mandate that the Prime Minister of India can.

**Statement II:** A candidate contesting for the post of President has to gain a majority of votes to be elected as President of India.

**Answer (4)**

41. If  $m = n^2 - n$ , where  $n$  is an integer, then  $m^2 - 2m$  is divisible by

- (1) 20                              (2) 24  
(3) 30                              (4) 16

**Answer (2)**

**Sol.**  $m = n^2 - n$

$$\Rightarrow m = n(n - 1)$$

$$m^2 - 2m = n(n - 1)(n^2 - n - 2) \\ = n(n - 1)(n - 2)(n + 1)$$

$\therefore$  Product of any four consecutive integers is always divisible by 24.

42. The value of  $\sqrt{97 \times 98 \times 99 \times 100 + 1}$  is equal to

- (1) 9901                          (2) 9891  
(3) 9801                          (4) 9701

**Answer (4)**

**Sol.** Let  $x = 97$

$$= \sqrt{x(x+1)(x+2)(x+3)+1}$$

$$= \sqrt{(x^2+3x)(x^2+3x+2)+1}$$

$$= \sqrt{(x^2+3x)^2+2(x^2+3x)+1}$$

$$= \sqrt{(x^2+3x+1)^2}$$

$$= x^2+3x+1$$

$$= (97)^2+3 \times 97+1 \quad [\because x = 97]$$

$$= 9701$$

43. Let  $P(x)$  be a polynomial of degree 3 and

$P(n) = \frac{1}{n}$  for  $n = 1, 2, 3, 4$ . Then the value of  $P(5)$  is

- (1) 0                                (2)  $\frac{1}{5}$   
(3)  $-\frac{2}{5}$                               (4)  $\frac{3}{5}$

**Answer (1)**

**Sol.**  $P(x)$  is a polynomial of degree 3.

$$n P(n) - 1 = 0$$

$$n(P(n)) = \text{polynomial of degree 4}$$

$$\therefore n P(n) - 1 = k(n - 1)(n - 2)(n - 3)(n - 4)$$

$$\text{for } n = 0,$$

$$-1 = 24 k$$

$$\Rightarrow k = \frac{-1}{24}$$



for  $n = 5$ ,

$$5 \cdot P(5) - 1 = \frac{-1}{24}(4)(3)(2)(1)$$

$$\Rightarrow 5 \cdot P(5) - 1 = -1$$

$$\Rightarrow P(5) = 0$$

44. If  $\alpha$  and  $\beta$  are the roots of the equation  $3x^2 - 5x + 3 = 0$ , then the quadratic equation whose roots are  $\alpha^2\beta$  and  $\alpha\beta^2$  is

(1)  $3x^2 - 5x + 3 = 0$       (2)  $3x^2 - 8x + 5 = 0$

(3)  $3x^2 - 8x + 3 = 0$       (4)  $3x^2 - 5x - 3 = 0$

**Answer (1)**

**Sol.**  $3x^2 - 5x + 3 = 0$

$$\therefore \alpha + \beta = \frac{5}{3}$$

$$\therefore \alpha\beta = 1$$

Required equation

$$x^2 - [\alpha\beta(\alpha + \beta)]x + (\alpha\beta)^3 = 0$$

$$\Rightarrow x^2 - \frac{5}{3}x + 1 = 0$$

$$\Rightarrow 3x^2 - 5x + 3 = 0$$

45. In village Madhubani 8 women and 12 girls can paint a large mural in 10 hours. 6 women and 8 girls can paint it in 14 hours. The number of hours taken by 7 women and 14 girls to paint the mural is

(1) 10                              (2) 15

(3) 20                              (4) 35

**Answer (1)**

**Sol.** Let one woman can paint in  $W$  hours and one girl can paint in  $G$  hours respectively.

According to question,

$$\frac{8}{W} + \frac{12}{G} = \frac{1}{10}$$

$$\Rightarrow \frac{2}{W} + \frac{3}{G} = \frac{1}{40} \quad \dots(i)$$

Also,  $\frac{6}{W} + \frac{8}{G} = \frac{1}{14}$

$$\Rightarrow \frac{3}{W} + \frac{4}{G} = \frac{1}{28} \quad \dots(ii)$$

On solving equation (i) and (ii), we get

$$W = 140 \text{ and } G = 280$$

$$\text{Now, } \frac{7}{140} + \frac{14}{280} = \frac{1}{\text{Time taken}}$$

$$\Rightarrow \frac{1}{T} = \frac{1}{20} + \frac{1}{20}$$

$$\Rightarrow T = 10 \text{ hours}$$

46. If  $x = \frac{3 + \sqrt{5}}{2}$  and  $y = x^3$ , then  $y$  satisfies the quadratic equation

(1)  $y^2 - 18y + 1 = 0$       (2)  $y^2 + 18y + 1 = 0$

(3)  $y^2 - 18y - 1 = 0$       (4)  $y^2 + 18y - 1 = 0$

**Answer (1)**

**Sol.**  $x = \frac{3 + \sqrt{5}}{2}$

$$\Rightarrow x^3 = \left(\frac{3 + \sqrt{5}}{2}\right)^3$$

$$\Rightarrow y = x^3 = 9 + 4\sqrt{5}$$

$\therefore$  One root is  $9 + 4\sqrt{5}$  and other is  $9 - 4\sqrt{5}$

$$\therefore \text{Sum of roots} = 9 + 4\sqrt{5} + 9 - 4\sqrt{5} = 18$$

$$\text{Product of roots} = (9 + 4\sqrt{5})(9 - 4\sqrt{5}) = 1$$

$\therefore$  Required equation,  $y^2 - 18y + 1 = 0$

47. If  $\tan^2\theta = 1 - e^2$ , then the value of  $\sec\theta + \tan^3\theta \operatorname{cosec}\theta$  is equal to

(1)  $(1 - e^2)^{1/2}$                       (2)  $(2 - e^2)^{1/2}$

(3)  $(2 - e^2)^{3/2}$                       (4)  $(1 - e^2)^{3/2}$

**Answer (3)**

**Sol.**  $\tan^2\theta = 1 - e^2$

$$\Rightarrow \sec\theta = \sqrt{1 + 1 - e^2} \quad [ \because \sec^2\theta = 1 + \tan^2\theta ]$$

$$\Rightarrow \sec\theta = \sqrt{2 - e^2} \quad \dots(i)$$

$$\therefore \sec\theta + \tan^3\theta \operatorname{cosec}\theta = \frac{1}{\cos\theta} (1 + \tan^2\theta)$$

$$= \frac{\sec^2\theta}{\cos\theta}$$

$$= \sec^3\theta$$

$$= (2 - e^2)^{3/2} \text{ [from (i)]}$$

48. Let the volume of a solid sphere be  $288\pi \text{ cm}^3$ . A horizontal plane cuts the sphere at a distance of 3 cm from the centre so that the ratio of the curved surface areas of the two parts of the sphere is 3 : 1. The total surface area of the bigger part of the sphere (in  $\text{cm}^2$ ) is

- (1)  $36\pi$  (2)  $108\pi$   
(3)  $135\pi$  (4)  $144\pi$

Answer (3)

Sol.

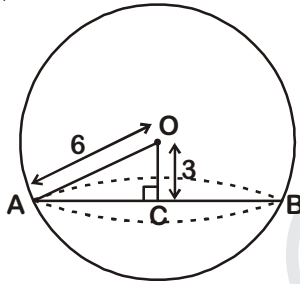

$$\frac{4}{3}\pi r^3 = 288\pi \quad (\because r = \text{radius of sphere})$$

$$\Rightarrow r = 6 \quad \dots(i)$$

OA is the radius of sphere

In  $\triangle AOC$ ,

$$AC = 3\sqrt{3} \text{ cm}$$

Curved surface area of bigger part =  $3x$

Curved surface area of smaller part =  $x$

$$3x + x = 4\pi r^2$$

$$\Rightarrow x = \pi r^2$$

$$\Rightarrow x = 36\pi \quad [\text{From (i)}]$$

Total surface area of bigger part

$$= 3x + \pi(3\sqrt{3})^2$$

$$= (108 + 27)\pi$$

$$= 135\pi \text{ cm}^2$$

49. A solid metallic cylinder of height 10 cm and diameter 14 cm is melted to make two cones in the proportion of their volumes as 3 : 4, keeping the height 10 cm, what would be the percentage increase in the flat surface area?

- (1) 9 (2) 16  
(3) 50 (4) 200

Answer (3)

Sol. Let  $r_1$  and  $r_2$  be the radii of two cones.

Volume of cylinder = Sum of volume of two cones

$$\pi \times 49 \times 10 = \frac{\pi}{3} \times 10(r_1^2 + r_2^2)$$

$$\Rightarrow r_1^2 + r_2^2 = 49 \times 3 \quad \dots(i)$$

$\therefore$  Percentage increase

$$= \frac{\pi r_1^2 + \pi r_2^2 - 2 \times \pi \times 49}{2 \times \pi \times 49} \times 100$$

$$= \frac{r_1^2 + r_2^2 - 2 \times 49}{2 \times 49} \times 100$$

$$= \frac{(49 \times 3 - 49 \times 2)}{49 \times 2} \times 100 \quad [\text{From (i)}]$$

$$= 50$$

50. Each vertical face of square based vertical pillar of height 3 m has 7 equal, semi-cylindrical surfaces in such a way that its horizontal cross-section is as shown in the figure.

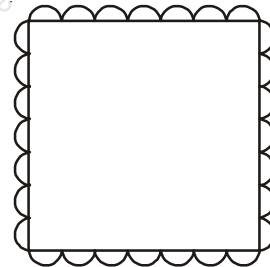

If the radius of each semi circle is 10 cm, the volume (in  $\text{m}^3$ ) of the pillar so designed

(taking  $\pi = \frac{22}{7}$ ) is

- (1) 5.88 (2) 6.14  
(3) 6.42 (4) 7.2

Answer (4)

Sol. Volume of Pillar = (Area of figure)  $\times$  height

$$= 3 \left[ (20 \times 7)^2 + 28 \times \frac{\pi r^2}{2} \right] \quad [\because 3 \text{ m} = 300 \text{ cm}]$$

$$= 300 \left( 19600 + 14 \times \frac{22}{7} \times 100 \right)$$

$$= 300(19600 + 4400)$$

$$= 300 \times 24000$$

$$= 7200000 \text{ cm}^3$$

$$= 7.2 \text{ m}^3$$

51. Let ABCD be a square of side 20 cm. The area of the square PQRS (in cm<sup>2</sup>) interior to ABCD, shown in the figure is

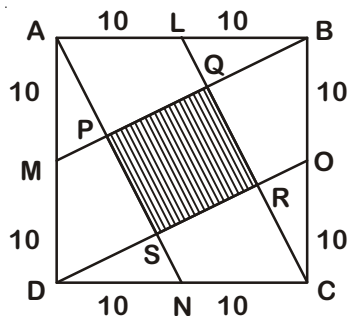

- (1) 60                      (2) 80  
(3) 100                    (4) 400

Answer (2)

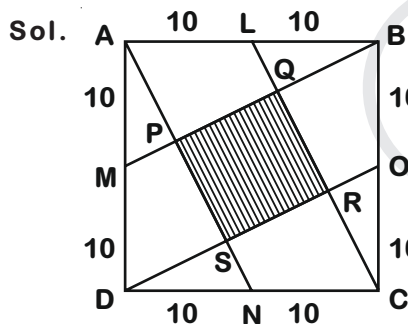

Sol.

BODM is a parallelogram

M is the mid-point of AD

∴ P is also the mid-point of AS (By mid-point theorem)

AP = PS = 2x [Let]

ΔAMP ≅ ΔDNS (By RHS congruence criterion)

SN = x

$$AN = \sqrt{400 + 100} = 10\sqrt{5}$$

$$\Rightarrow 5x = 10\sqrt{5}$$

$$\Rightarrow x = 2\sqrt{5}$$

$$PS = 4\sqrt{5}$$

$$\begin{aligned} \text{Area of PQRS} &= (4\sqrt{5})^2 \\ &= 80 \text{ cm}^2 \end{aligned}$$

52. A circle is inscribed in a right angled triangle of perimeter  $7\pi$ . Then the ratio of numerical values of circumference of the circle to the area of the right angled triangle is

- (1) 4 : 7                      (2) 3 : 7  
(3) 2 : 7                      (4) 1 : 7

Answer (1)

Sol.

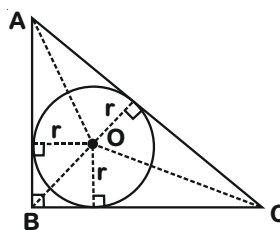

$$\begin{aligned} \text{Area of } \triangle ABC &= [\text{ar}(\triangle AOB) + \text{ar}(\triangle BOC) \\ &\quad + \text{ar}(\triangle AOC)] \end{aligned}$$

$$= \frac{1}{2} AB \times r + \frac{1}{2} BC \times r + \frac{1}{2} AC \times r$$

$$= \frac{1}{2} r [AB + BC + AC]$$

$$= \frac{1}{2} r \times 7\pi$$

$$\therefore \frac{\text{Circumference of circle}}{\text{Area of triangle}} = \frac{2\pi r}{\frac{1}{2} r \times 7\pi}$$

$$= \frac{4}{7}$$

$$= 4 : 7$$

53. It is known that area of a cyclic quadrilateral is  $\sqrt{(s-a)(s-b)(s-c)(s-d)}$  where a, b, c, d

are the sides and  $s = \frac{a+b+c+d}{2}$ .

If a circle can also be inscribed in the cyclic quadrilateral then the area of this quadrilateral is

(1)  $\sqrt{(ab)^2 + (cd)^2}$                       (2)  $\sqrt{abcd}$

(3)  $\sqrt{(ac)^2 + (bd)^2}$                       (4)  $\sqrt{(ad)^2 + (bc)^2}$

Answer (2)

Sol.

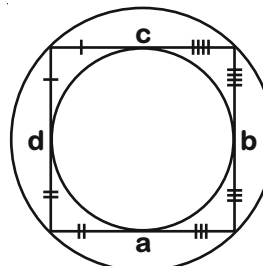

$$a + c = b + d = x$$

$$s = \frac{a+b+c+d}{2}$$

$$= \frac{2x}{2} = x$$

$$\text{Area} = \sqrt{(s-a)(s-b)(s-c)(s-d)}$$

$$= \sqrt{(a+c-a)(b+d-b)(a+c-c)(b+d-d)}$$

$$= \sqrt{(c)(d)(a)(b)}$$

$$= \sqrt{abcd}$$

54. Two circles, both of radii  $a$  touch each other and each of them touches internally a circle of radius  $2a$ . Then the radius of the circle which touches all the three circles is

(1)  $\frac{1}{2}a$

(2)  $\frac{2}{3}a$

(3)  $\frac{3}{4}a$

(4)  $a$

Answer (2)

Sol.

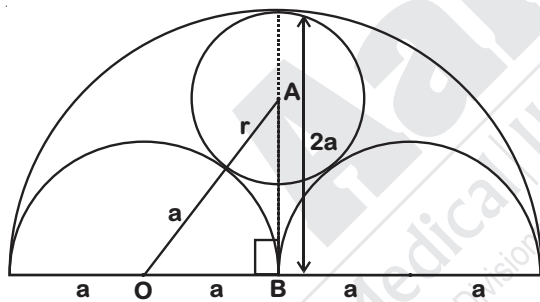

In  $\triangle AOB$

$$(a+r)^2 = (2a-r)^2 + a^2$$

$$\Rightarrow a^2 + 2ar + r^2 = 4a^2 + r^2 - 4ar + a^2$$

$$\Rightarrow 6ar = 4a^2$$

$$\Rightarrow r = \frac{2a}{3}$$

55. Let  $D$  be a point on the side  $BC$  of a triangle  $ABC$  such that  $\angle ADC = \angle BAC$ . If  $AC = 21$  cm, then the side of an equilateral triangle whose area is equal to the area of the rectangle with sides  $BC$  and  $DC$  is

(1)  $14 \times 3^{1/2}$

(2)  $42 \times 3^{-1/2}$

(3)  $14 \times 3^{3/4}$

(4)  $42 \times 3^{1/2}$

Answer (3)

Sol.

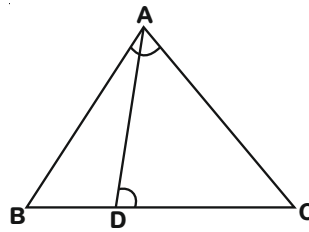

$$\triangle ABC \sim \triangle DAC$$

$$\Rightarrow \frac{BC}{AC} = \frac{AC}{DC}$$

$$\Rightarrow BC \times DC = AC^2$$

$$\Rightarrow BC \times DC = (21)^2$$

Area of equilateral triangle = Area of rectangle

$$\frac{\sqrt{3}}{4} (\text{side})^2 = (21)^2$$

$$\Rightarrow \text{Side} = 14 \times 3^{3/4}$$

56. Let  $ABC$  be a triangle with sides  $a, b, c$ . Then lengths of medians of the triangle formed by the medians of the triangle  $ABC$  are

(1)  $\frac{1}{2}a, \frac{1}{2}b, \frac{1}{2}c$

(2)  $\frac{2}{3}a, \frac{2}{3}b, \frac{2}{3}c$

(3)  $\frac{3}{4}a, \frac{3}{4}b, \frac{3}{4}c$

(4)  $\frac{5}{6}a, \frac{5}{6}b, \frac{5}{6}c$

Answer (3)

Sol. Lengths of medians of  $\triangle ABC$  are

$$M_a = \frac{1}{2} \sqrt{2b^2 + 2c^2 - a^2}$$

$$M_b = \frac{1}{2} \sqrt{2c^2 + 2a^2 - b^2}$$

$$M_c = \frac{1}{2} \sqrt{2a^2 + 2b^2 - c^2}$$

Let length of median of triangle formed by these medians  $p, q, r$

$$p = \frac{1}{2} \sqrt{2M_b^2 + 2M_c^2 - M_a^2}$$

$$\Rightarrow p = \frac{3}{4}a$$

Similarly,  $q = \frac{3}{4}b$

$$r = \frac{3}{4}c$$

57.  $(x + 1)^4$  is divided by  $(x - 1)^3$ . Then the value of the remainder at  $x = 1$  is

- (1) -16                      (2) 0  
(3) 16                        (4) 32

Answer (3)

Sol.  $(x + 1)^4 = x^4 + 4x^3 + 6x^2 + 4x + 1$   
 $(x - 1)^3 = x^3 - 3x^2 + 3x - 1$

$$\begin{array}{r} x^3 - 3x^2 + 3x - 1 \overline{) x^4 + 4x^3 + 6x^2 + 4x + 1} \phantom{(x + 7)} \\ \underline{- x^3 + 3x^2 - 3x + 1} \phantom{(x + 7)} \\ 7x^3 + 3x^2 + 5x + 1 \phantom{(x + 7)} \\ \underline{- 7x^3 + 21x^2 - 21x + 7} \phantom{(x + 7)} \\ 24x^2 - 16x + 8 \phantom{(x + 7)} \end{array}$$

At  $x = 1$ ,

Remainder =  $24 - 16 + 8 = 16$

58. A circle passes through the vertices of a triangle ABC. If the vertices are A(-2, 5), B(-2, -3), C(2, -3), then the centre of the circle is

- (1) (0, 0)  
(2) (0, 1)  
(3) (-2, 1)  
(4) (0, -3)

Answer (2)

Sol.

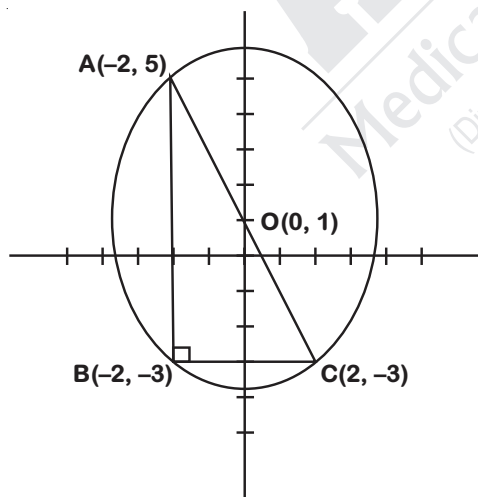

AC is the diameter of the circle

O is the centre of the circle

$$= \left( \frac{-2+2}{2}, \frac{5-3}{2} \right)$$

$$= (0, 1)$$

59. If two dice are thrown together, the probability that the difference of the numbers appearing on them is a prime number

- (1)  $\frac{2}{9}$                       (2)  $\frac{4}{9}$   
(3)  $\frac{5}{12}$                     (4)  $\frac{17}{36}$

Answer (2)

Sol. Favourable outcomes = (1, 3) (2, 4) (3, 1) (4, 1) (5, 2) (6, 1) (1, 4), (2, 5) (3, 5) (4, 2) (5, 3) (1, 6) (3, 6) (4, 6) (6, 3) (6, 4)

No. of favourable outcomes = 16

Required probability =  $\frac{16}{36} = \frac{4}{9}$

60. Observe the following data.

Class	0-20	20-40	40-60	60-80	80-100	Total
Frequency	17	$f_1$	32	$f_2$	19	120

If the above data has mean 50, then missing frequencies  $f_1$  and  $f_2$  are respectively

- (1) 28 and 24                      (2) 24 and 28  
(3) 28 and 30                      (4) 30 and 28

Answer (1)

Sol.

Class	frequency( $f_i$ )	Mid-values( $x_i$ )	$f_i x_i$
0-20	17	10	170
20-40	$f_1$	30	$30 f_1$
40-60	32	50	1600
60-80	$f_2$	70	$70 f_2$
80-100	19	90	1710
Total	120		

$$17 + 19 + 32 + f_1 + f_2 = 120$$

$$\Rightarrow f_1 + f_2 = 52 \quad \dots(i)$$

$$\therefore \text{mean} = \frac{\sum f_i x_i}{\sum f_i}$$

$$\frac{3480 + 30 f_1 + 70 f_2}{120} = 50$$

$$\Rightarrow 3 f_1 + 7 f_2 = 252 \quad \dots(ii)$$

from (i) and (ii)

$$3 f_1 + 7 f_2 = 252$$

$$3 f_1 + 3 f_2 = 156$$

$$\underline{\hspace{1.5cm}}$$

$$4 f_2 = 96$$

$$\Rightarrow f_2 = 24$$

$$f_1 = 52 - 24 = 28$$

**Directions: (Questions 61 - 62)**

Suppose that the acceleration versus time graph of a particle that starts from rest at  $t = 0$  is as shown in the figure.

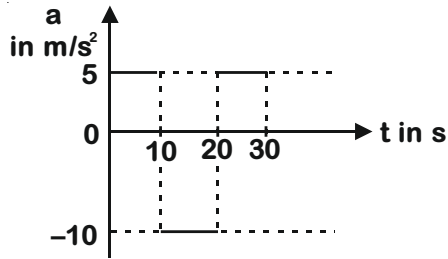

61. At what instant does the particle come to rest for the first time?
- (1) 5 s
  - (2) 10 s
  - (3) 15 s
  - (4) The particle never comes to rest

**Answer (3)**

**Sol.** Since area under acceleration-time graph gives change in velocity

Let at time  $t$  speed become zero, then

$$5 \times 10 - 10 \times (t - 10) = 0$$

$$50 - 10t + 100 = 0$$

$$t = \frac{150}{10}$$

$$t = 15 \text{ s}$$

62. What is the total distance travelled by the particle during 30 s?
- (1) 0 m
  - (2) 500 m
  - (3) 750 m
  - (4) 1000 m

**Answer (3)**

**Sol.**  $S_{1-10} = S_1 = \frac{1}{2} \times 5 \times (10)^2 = 250 \text{ m}$

$$S_{10-15} = S_2 = \frac{(50)^2}{2 \times 10} = 125 \text{ m}$$

$$S_{15-20} = S_3 = \frac{(50)^2}{2 \times 10} = 125 \text{ m}$$

$$S_{20-30} = S_4 = \frac{(50)^2}{2 \times 5} = 250 \text{ m}$$

$$S_{\text{net}} = S_1 + S_2 + S_3 + S_4$$

$$S_{\text{net}} = 250 + 125 + 125 + 250$$

$$S_{\text{net}} = 750 \text{ m}$$

63. An object of mass 2 kg is moving under the action of a force which varies with time as shown in the figure.

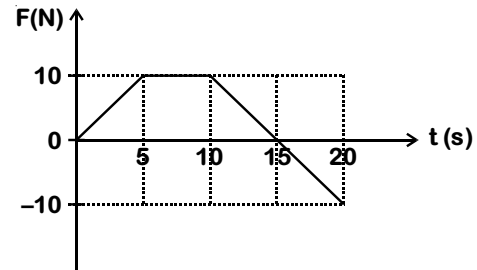

Which one of the following statements is correct for the interval from 0 to 20 s?

- (1) The momentum of the object decreases by 75 kg m/s.
- (2) The momentum of the object increases by 75 kg m/s.
- (3) The momentum of the object increases by 125 kg m/s.
- (4) The change in momentum cannot be found as initial speed is unknown.

**Answer (2)**

**Sol.** Area under force time graph gives change in momentum

$$\Delta p = \frac{1}{2} \times (15 + 5) \times 10 - \frac{1}{2} \times 10 \times 5$$

$$\Delta p = 100 - 25$$

$$\Delta p = 75 \text{ kg m/s}$$

64. Two cars 'A' and 'B' of same mass start from the same location at the same time out on different straight roads. Car 'A' travels on a road that has greater angle of inclination with horizontal compared to the road on which 'B' travels.

At any instant both cars 'A' and 'B' have the same height above the starting point. If  $E_A$  and  $E_B$  are total energies of cars 'A' and 'B' respectively, then

- (1)  $E_A < E_B$
- (2)  $E_A = E_B$
- (3)  $E_A > E_B$
- (4) Relation between  $E_A$  and  $E_B$  cannot be decided based on given information.

**Answer (1)**

**Sol.** For vertical direction

$$h = \frac{1}{2} a_A \sin \theta_A t^2 = \frac{1}{2} a_B \sin \theta_B t^2$$

$$\frac{a_A}{a_B} = \frac{\sin \theta_B}{\sin \theta_A}$$

$$\therefore \sin \theta_A > \sin \theta_B$$

$$\frac{a_A}{a_B} < 1$$

$$a_A < a_B$$

Along the plane

$$v_A = a_A \times t$$

$$v_B = a_B \times t$$

$$\frac{v_A}{v_B} = \frac{a_A}{a_B} < 1$$

$$v_A < v_B$$

$$E_A = mgh + \frac{1}{2} mv_A^2$$

$$E_B = mgh + \frac{1}{2} mv_B^2$$

$$E_B > E_A$$

65. The gravitational potential energy difference per unit mass between the surface of a planet and a point 100 m above it is 1000 J/kg. How much work is required to be done in moving a 5 kg object 100 m on a slope at 30° to the horizontal on this planet?

- (1) 1250 J                      (2) 2500 J  
(3) 4350 J                      (4) 5000 J

**Answer (2)**

**Sol.**  $\frac{\Delta U}{m} = \frac{mg'(h_2 - h_1)}{m} = g'h$

$$\frac{\Delta U}{m} = g'h = 1000 \text{ J/Kg}$$

$$g' = 10 \text{ m/s}^2$$

$$h = 100 \sin 30^\circ$$

$$h = 50 \text{ m}$$

$$U = mg'h$$

$$U = 5 \times 10 \times 50$$

$$U = 2500 \text{ J}$$

**Directions : (Questions 66 - 67)**

Two identical objects A and B each of mass  $m$  start moving along the same vertical line in opposite directions at the same instant. Object A is dropped from rest from a height  $H$  above the ground and object B is projected vertically upward from the ground with speed  $u = \sqrt{2gH}$ .

66. At what height above the ground do they collide?

- (1)  $(1/4) H$   
(2)  $(1/2) H$   
(3)  $(2/3) H$   
(4)  $(3/4) H$

**Answer (4)**

**Sol.** For object A

$$x = \frac{1}{2} gt^2 \quad \dots(i)$$

For object B

$$H - x = ut - \frac{1}{2} gt^2$$

$$H - x = (\sqrt{2gH})t - \frac{1}{2} gt^2 \quad \dots(ii)$$

By adding (i) and (ii)

$$t = \sqrt{\frac{H}{2g}}$$

$$\text{Height } (H - x) = H - \frac{1}{2} g \left( \sqrt{\frac{H}{2g}} \right)^2$$

$$= H - \frac{1}{2} \times g \times \frac{H}{2g}$$

$$= \frac{3H}{4}$$

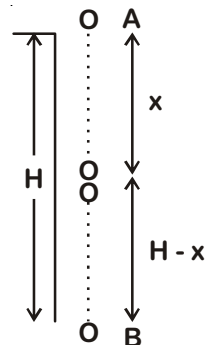

67. After they collide, they stick to each other. What is the loss in their total energy?

- (1) 0  
(2)  $(1/2) mgH$   
(3)  $(3/2) mgH$   
(4)  $2 mgH$

**Answer (2)**

Sol.  $v_A = 2\sqrt{\frac{H}{2g}}$   
 $= \sqrt{\frac{gH}{2}}$

$v_B = \sqrt{2gH} - g \times \sqrt{\frac{H}{2g}}$   
 $= \sqrt{2gH} - \sqrt{\frac{gH}{2}}$   
 $= \sqrt{gH} \left( \sqrt{2} - \frac{1}{\sqrt{2}} \right)$

$v_B = \sqrt{\frac{gH}{2}}$

$P_i = P_f$

$m\sqrt{\frac{gH}{2}} - m\sqrt{\frac{gH}{2}} = 2mv_f$

$v_f = 0$

$E_i = mgH + \frac{1}{2} \times m \times (\sqrt{2gH})^2$

$E_i = 2mgH$

$E_f = (2m) \frac{3H}{4} \times g = \frac{3mgH}{2}$

$\Delta E = \frac{1}{2} mgH$

68. Given below are two different graphs of variation of density (or pressure) of the medium with position (Fig. 1) and with time (Fig. 2) as a wave passes through the medium.

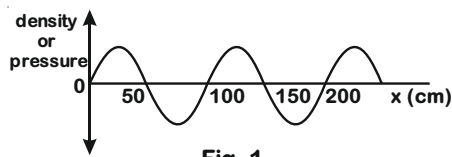

Fig. 1

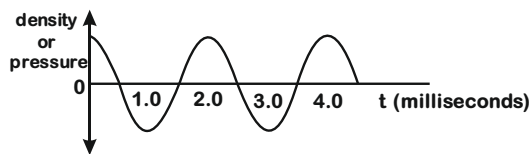

Fig. 2

What will be the speed of the wave in the given medium?

- (1) 25 m/s                      (2) 50 m/s  
 (3) 250 m/s                    (4) 500 m/s

**Answer (4)**

Sol.  $\lambda = 100 \text{ cm}$

$T = 2 \times 10^{-3} \text{ s}$

$v = \frac{\lambda}{T}$

$= \frac{100 \times 10^{-2}}{2 \times 10^{-3}}$

$= 500 \text{ m/s}$

69. A convex lens and a concave lens, each of focal length 10 cm, are kept separated by a distance of 2 cm as shown in the figure. If the light is incident from left, the combinations of lenses will be \_\_\_\_\_.

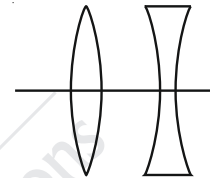

- (1) Converging  
 (2) Diverging  
 (3) Behaving like a glass slab  
 (4) Converging or diverging depending on whether the lenses are arranged as shown in the figure or in the reverse order.

**Answer (1)**

Sol.  $\frac{1}{f} = \frac{1}{f_1} + \frac{1}{f_2} - \frac{d}{f_1 f_2}$

$\frac{1}{f} = \frac{1}{10} - \frac{1}{10} - \frac{2}{100}$

$\frac{1}{f} = \frac{2}{100}$

$f = +50 \text{ cm (converging lens)}$

70. In the circuit given, the ratio of work done by the battery to maintain the current between point A and B to the work done for the whole circuit is

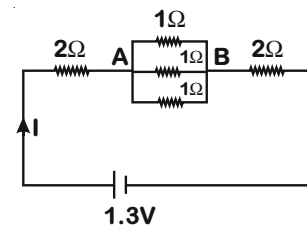

- (1)  $\frac{1}{117}$                       (2)  $\frac{1}{13}$   
 (3)  $\frac{1}{12}$                       (4) 1

**Answer (2)**



Sol. Circuit can be redrawn as

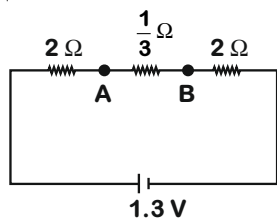

$$R_{eq} = 2 + \frac{1}{3} + 2 = \frac{13}{3} \Omega$$

$$W_{circuit} = \frac{V^2}{R} t$$

$$= \frac{(1.3)^2}{\frac{13}{3}} t$$

$$= 0.39t$$

$$\therefore V_{AB} = \frac{\frac{1}{3}}{\frac{13}{3}} \times 1.3$$

$$= 0.1 V$$

$$W_{AB} = \frac{V_{AB}^2}{R} t$$

$$= \frac{(0.1)^2}{\frac{1}{3}} t$$

$$= 0.03 t$$

$$\frac{W_{AB}}{W_{circuit}} = \frac{0.03t}{0.39t} = \frac{1}{13}$$

71. Magnetic field at the centre of a circular coil of radius  $R$  carrying current  $i$  is  $B \propto \frac{i}{R}$  and its direction is given by right-hand thumb rule.

Magnetic field at the centre of a circular arc subtending an angle  $\theta$  (in degree) is  $B \propto \frac{i}{R} \left( \frac{\theta}{360^\circ} \right)$  and its direction can be found using right hand rule.

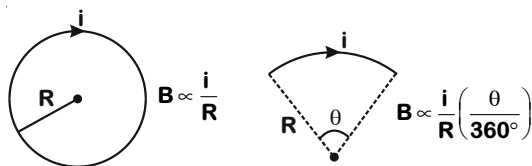

Consider two circular coils made of uniform conductors as shown in figure 3 and 4. In figure 3 points C and D are diametrically opposite to each other, and in figure 4  $\angle PO_2Q = 120^\circ$ .

Then magnetic fields \_\_\_\_\_.

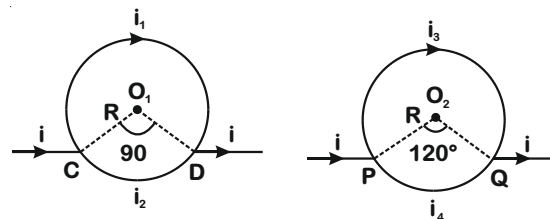

- (1) At both  $O_1$  and  $O_2$  are zero
- (2) At both  $O_1$  and  $O_2$  are non-zero
- (3) At zero at  $O_1$  but non-zero at  $O_2$
- (4) Is non-zero at  $O_1$  but zero at  $O_2$

Answer (1)

Sol. For figure - 3

$$i_1 = i \times \frac{\pi r}{2\pi r} = \frac{i}{4}$$

$$i_2 = i \times \frac{3\pi r}{2\pi r} = \frac{3i}{4}$$

$$B_1 = k \cdot \frac{i}{4} \times \frac{1}{R} \times \frac{270^\circ}{360^\circ}$$

$$B_1 = k \cdot \frac{3i}{16R} \text{ (inward)}$$

Similarly

$$B_2 \propto \frac{3i}{4} \times \frac{1}{R} \times \frac{90^\circ}{360^\circ} \text{ (outward)}$$

$$B_2 = k \cdot \frac{3i}{16R} \text{ (outward)}$$

$$B_{net} = B_1 - B_2 = 0$$

Here we can conclude that current so divided in the branch that net magnetic field at centre remains zero.

So, net magnetic field will be zero at the centre of both loop.

72. A pin AB of length 2 cm is kept on the axis of a convex lens between 18 cm and 20 cm as shown in figure. Focal length of convex lens is 10 cm. Find magnification produced for the image of the pin.

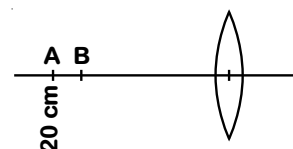

(1) 0.83

(2) 1.00

(3) 1.25

(4) 6.78

Answer (3)

Sol. For end A

$$u_1 = -20 \text{ cm}$$

$$f = 10 \text{ cm}$$

$$\therefore \frac{1}{f} = \frac{1}{v} - \frac{1}{u}$$

$$\frac{1}{10} = \frac{1}{v_1} - \frac{1}{(-20)}$$

$$\frac{1}{v_1} = \frac{1}{10} - \frac{1}{20} = \frac{1}{20}$$

$$v_1 = 20 \text{ cm}$$

For end B

$$u_2 = -18$$

$$\frac{1}{10} = \frac{1}{v_2} - \frac{1}{-18}$$

$$\frac{1}{v_2} = \frac{1}{10} - \frac{1}{18} = \frac{8}{180}$$

$$v_2 = 22.5 \text{ cm}$$

$$\text{Length of image} = 22.5 - 20 = 2.5 \text{ cm}$$

$$\text{Magnification } m = \frac{2.5}{2} = 1.25$$

73. What is the current supplied by the battery in the circuit shown below? Each resistance used in circuit is of  $1 \text{ k}\Omega$  and potential difference  $V_{AB} = 8\text{V}$

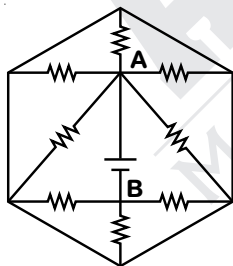

- (1) 64 mA                      (2) 15 mA  
(3) 9.87 mA                  (4) 1 mA

Answer (2)

Sol. Circuit can be redrawn as

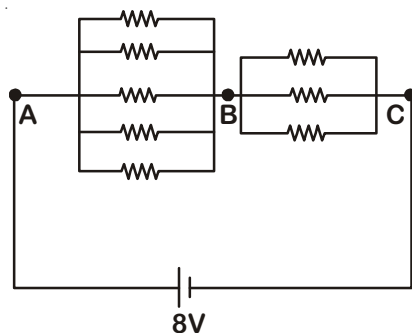

$$R_{\text{net}} = \frac{1000}{5} + \frac{1000}{3}$$

$$R_{\text{net}} = \frac{8000}{15} \Omega$$

$$I = \frac{8 \times 15}{8000} = 15 \text{ mA}$$

74. Read the following statements.

**Statement I** : Sodium metal reacts violently with water to produce heat and fire.

**Statement II** : Potassium metal reacts violently with water to form potassium hydroxide and hydrogen gas.

Select the correct answer from the options given below.

- (1) Statement I is true, Statement II is false  
(2) Statement I is false, Statement II is true  
(3) Both statements are true, and Statement II provides explanation to Statement I  
(4) Both statements are true but Statement II does not provides explanation to Statement I

Answer (4)

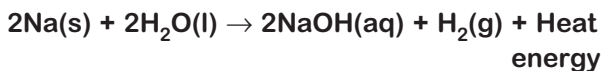
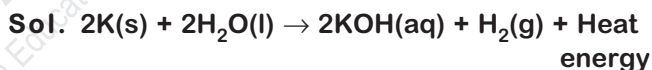

75. You are provided with 18 g each of  $\text{O}_2$ ,  $\text{N}_2$ ,  $\text{CH}_4$  and  $\text{H}_2\text{O}$ . Which of the following is the correct decreasing order of number of atoms present in these samples?

- (1)  $\text{CH}_4 > \text{H}_2\text{O} > \text{N}_2 > \text{O}_2$   
(2)  $\text{O}_2 > \text{N}_2 > \text{H}_2\text{O} > \text{CH}_4$   
(3)  $\text{CH}_4 > \text{N}_2 > \text{O}_2 > \text{H}_2\text{O}$   
(4)  $\text{N}_2 > \text{H}_2\text{O} > \text{O}_2 > \text{CH}_4$

Answer (1)

Sol. No. of atoms in  $\text{O}_2 = \frac{18}{32} \times 2N_A = 1.12 N_A$

No. of atoms in  $\text{N}_2 = \frac{18}{28} \times 2N_A = 1.28 N_A$

No. of atoms in  $\text{CH}_4 = \frac{18}{16} \times 5N_A = 5.62 N_A$

No. of atoms in  $\text{H}_2\text{O} = \frac{18}{18} \times 3N_A = 3.0 N_A$

76. Manya, Kartik, Gurnoor and Sheena had arranged the ions  $F^-$ ,  $Na^+$ ,  $O^{2-}$  and  $Mg^{2+}$  in decreasing orders of their ionic radii.

Manya –  $O^{2-} > Mg^{2+} > F^- > Na^+$

Kartik –  $Mg^{2+} > Na^+ > O^{2-} > F^-$

Gurnoor –  $O^{2-} > F^- > Na^+ > Mg^{2+}$

Sheena –  $F^- > Na^+ > O^{2-} > Mg^{2+}$

Who had provided the correct order of their decreasing ionic radii?

- (1) Manya
- (2) Kartik
- (3) Gurnoor
- (4) Sheena

Answer (3)

Sol. Among isoelectronic species, the one with the larger positive nuclear charge will have a smaller radius.

77. An organic compound A on heating with concentrated  $H_2SO_4$  gave product B and on warming with alkaline  $KMnO_4$  gave compound C. Compound A on heating with compound C in presence of concentrated  $H_2SO_4$  formed compound D, which has fruity smell.

Identify the compounds A, B, C and D:

- (1) A = Alcohol, B = Carboxylic acid,  
C = Alkene, D = Ester
- (2) A = Carboxylic acid, B = Ester,  
C = Alkene, D = Alcohol
- (3) A = Alcohol, B = Alkene,  
C = Carboxylic acid, D = Ester
- (4) A = Alkene, B = Alcohol, C = Ester,  
D = Carboxylic acid

Answer (3)

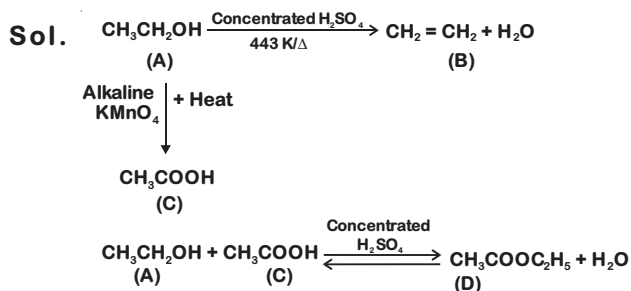

78. Match List I (Mixture) and List II (Type) with the List III (Example) and select the correct answer from the combinations given below:

List I (Mixture)	List II (Type)	List III (Example)
A. Liquid in gas	1. Emulsion	I. Mist
B. Liquid in liquid	2. Aerosol	II. Sponge
C. Gas in solid	3. Foam	III. Face cream
	4. Gel	IV. Butter

- (1) A-3-II, B-2-III, C-4-IV
- (2) A-2-I, B-1-III, C-3-II
- (3) A-1-III, B-2-II, C-3-I
- (4) A-1-II, B-4-I, C-2-III

Answer (2)

Sol.

Mixture	Type	Example
A. Liquid in gas	2. Aerosol	I. Mist
B. Liquid in liquid	1. Emulsion	III. Face cream
C. Gas in solid	3. Foam	II. Sponge

79. Which of the following set of reactions will NOT occur?

- I.  $MgSO_4(aq) + Fe(s) \rightarrow FeSO_4(aq) + Mg(s)$
  - II.  $CuSO_4(aq) + Fe(s) \rightarrow FeSO_4(aq) + Cu(s)$
  - III.  $MgSO_4(aq) + Cu(s) \rightarrow CuSO_4(aq) + Mg(s)$
  - IV.  $CuSO_4(aq) + Zn(s) \rightarrow ZnSO_4(aq) + Cu(s)$
- (1) I and III
  - (2) II and IV
  - (3) I, II and III
  - (4) II, III and IV

Answer (1)

Sol. A more reactive metal displaces a less reactive metal from its salt solution.

According to the reactivity series

$Mg > Zn > Fe > Cu$

80. Two organic compounds 'A' and 'B' react with sodium metal and both produce the same gas 'X', but with sodium hydrogen carbonate only compound B reacts to give a gas 'Y'. Identify 'A', 'B', 'X' and 'Y':

- (1) A = Ethylene, B = Ethyl alcohol,  
X = Carbon dioxide, Y = Hydrogen
- (2) A = Ethyl alcohol, B = Acetic acid,  
X = Hydrogen, Y = Carbon dioxide
- (3) A = Methyl alcohol, B = Ethyl alcohol,  
X = Hydrogen, Y = Carbon dioxide
- (4) A = Acetic acid, B = Formic acid,  
X = Carbon dioxide, Y = Hydrogen

Answer (2)

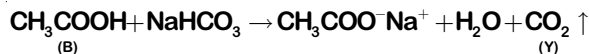
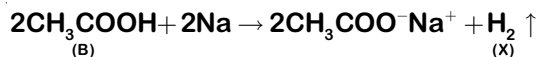
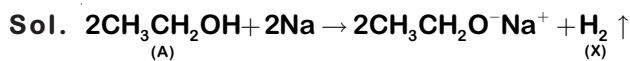

81. Consider the elements A, B, C and D with atomic numbers 11, 12, 16 and 17, respectively. Which among the following statements regarding these elements are correct?

- I. The element C will gain electron more easily than element D.
- II. The element B tends to lose electron more readily than C.
- III. The oxide of A will be least basic while that of D will be most basic.
- IV. The energy required to remove an electron from outermost shell from A will be minimum while that from D will be maximum.

- (1) I and III only      (2) I and IV only  
(3) II and III only      (4) II and IV only

Answer (4)

Sol.	Element	Electronic configuration
A(11)	Na	2, 8, 1
B(12)	Mg	2, 8, 2
C(16)	S	2, 8, 6
D(17)	Cl	2, 8, 7

- Chlorine (D) will gain electrons more easily than sulphur (C)
- The oxide of sodium (A) will be most basic while that of chlorine (D) will be most acidic

82. The following observations are given for four metals:

- I. Metal H does not react with dilute HCl.
- II. Metal K reacts with warm water.
- III. Metal L does not react with water but displaces metal H from its aqueous salt solution.
- IV. Metal M reacts with cold water.

Choose the correct decreasing order of reactivity of these metals amongst the following:

- (1)  $M > L > H > K$       (2)  $K > M > H > L$   
(3)  $M > K > L > H$       (4)  $L > H > K > M$

Answer (3)

Sol. As per the given information H, K, L and M can be identified as Cu, Mg, Pb and K/Na respectively. So their reactivity order will be  $M > K > L > H$  ( $K > \text{Mg} > \text{Pb} > \text{Cu}$ )

83. Match chemical reactions given in the List I with the type of chemical reactions given in List II and select the correct answer using the options given below:

List I (Chemical Reactions)	List II (Type of Chemical Reactions)
A. Formation of $\text{NH}_3$ from $\text{N}_2$ and $\text{H}_2$	I. Decomposition
B. Calcination of zinc carbonate	II. Double displacement
C. Reaction of aqueous $\text{BaCl}_2$ solution with dilute $\text{H}_2\text{SO}_4$	III. Combination
D. Rancidity of oils	IV. Redox
	V. Displacement

- (1) A-I, B-V, C-III, D-IV  
(2) A-III, B-IV, C-V, D-I  
(3) A-IV, B-III, C-V, D-I  
(4) A-III, B-I, C-II, D-IV

Answer (4)

Sol.	List I (Chemical Reactions)	List II (Type of Chemical Reactions)
	A. Formation of $\text{NH}_3$ from $\text{N}_2$ and $\text{H}_2$ ( $\text{N}_2 + 3\text{H}_2 \rightleftharpoons 2\text{NH}_3$ )	III. Combination
	B. Calcination of zinc carbonate ( $\text{ZnCO}_3 \xrightarrow{\Delta} \text{ZnO} + \text{CO}_2$ )	I. Decomposition
	C. Reaction of aqueous $\text{BaCl}_2$ solution with dilute $\text{H}_2\text{SO}_4$ ( $\text{BaCl}_2 + \text{H}_2\text{SO}_4 \rightarrow \text{BaSO}_4 + 2\text{HCl}$ )	II. Double displacement
	D. Rancidity of oils	IV. Redox

84. You are provided with aqueous solutions of three salts — A, B and C, 2-3 drops of blue litmus solution, red litmus solution, and phenolphthalein were added to each of these solution in separate experiments. The change in colours of different indicators were recorded in the following table:

Sample	With Blue Litmus Solution	With Red Litmus Solution	With Phenolphthalein Solution
A	No Change	No Change	No Change
B	Turns Red	No Change	No Change
C	No Change	Turns blue	Turns pink

On the basis of above observations, identify A, B, and C from the following options:

- (1) A =  $\text{NH}_4\text{Cl}$ , B =  $\text{NaCl}$ , C =  $\text{CH}_3\text{COONa}$
- (2) A =  $\text{NH}_4\text{Cl}$ , B =  $\text{CH}_3\text{COONa}$ , C =  $\text{NaCl}$
- (3) A =  $\text{NaCl}$ , B =  $\text{NH}_4\text{Cl}$ , C =  $\text{CH}_3\text{COONa}$
- (4) A =  $\text{CH}_3\text{COONa}$ , B =  $\text{NH}_4\text{Cl}$ , C =  $\text{NaCl}$

Answer (3)

Sol.

Aqueous solutions of	With blue litmus solution	With red litmus solution	With Phenolphthalein solution
Neutral salt ( $\text{NaCl}$ )	No change	No change	No change
Acidic salt ( $\text{NH}_4\text{Cl}$ )	Turns red	No change	No change
Basic salt ( $\text{CH}_3\text{COONa}$ )	No change	Turns blue	Turns pink

85. Match List I (Mixture to be Separated) with the List II (Method Used) and select the correct answer using the options given below.

List I (Mixture to be Separated)	List II (Method Used)
A. Liquid $\text{N}_2$ and liquid $\text{O}_2$	I. Chromatography
B. Red and Blue inks	II. Sublimation
C. Solution of $\text{NaCl}$ in water	III. Fractional Distillation
D. Naphthalene and $\text{NaCl}$	IV. Evaporation V. Crystallisation

- (1) A — I, B — II, C — IV, D — V
- (2) A — III, B — V, C — II, D — IV
- (3) A — III, B — I, C — IV, D — II
- (4) A — III, B — IV, C — I, D — II

Answer (3)

Sol.

(Mixture to be Separated)	(Method Used)
A. Liquid $\text{N}_2$ and liquid $\text{O}_2$	III. Fractional distillation
B. Red and Blue inks	I. Chromatography
C. Solution of $\text{NaCl}$ in water	IV. Evaporation
D. Naphthalene and $\text{NaCl}$	II. Sublimation

86. Select the correct set of statements regarding change in properties, as we move down the second group in periodic table.

- I. Atomic size increases.
- II. Electronegativity increases.
- III. Tendency to lose electrons increases.
- IV. Valency remains same.

- (1) I, II and III
- (2) II, III and IV
- (3) I, II and IV
- (4) I, III and IV

Answer (4)

Sol.

S. No.	Property	Trend down the group
1.	Atomic size	Increases
2.	Electronegativity	Decreases
3.	Tendency to lose electrons	Increases
4.	Valency	Remains same

87. Which of the following options containing formula, bonding and nature of aqueous solution respectively is correct for the compound formed by two elements A and B having atomic numbers 1 and 17, respectively?

- (1)  $\text{AB}$ , Ionic, Acidic
- (2)  $\text{AB}_2$ , Ionic, Basic
- (3)  $\text{AB}$ , Covalent, Acidic
- (4)  $\text{AB}_2$ , Covalent, Neutral

Answer (3)

**Sol.** Elements A and B are hydrogen and chlorine respectively.

Chemical formula – HCl (AB)

Bonding – Covalent  $\left( \begin{array}{c} \text{H} \\ \text{---} \\ \text{Cl} \end{array} \right) \text{ or } \text{H-Cl}$

Nature of aqueous solution – Acidic

(Aqueous solution of HCl turns blue litmus red)

88. Choose one of the following alternative statements given below which correctly explains the process of osmosis.

- (1) Movement of water from regions of concentrated to dilute solutions
- (2) The passage of solute from weak solution to strong solution through a selectively-permeable membrane
- (3) A passive transport of a solvent through a selectively-permeable membrane from a region of low solute concentration to a region of high solute concentration
- (4) An energy-dependent transport of a solvent through a selectively-permeable membrane from a region of low solute concentration to a region of high solute concentration

**Answer (3)**

**Sol.** Osmosis can be explained as “The movement of solvent (water) from a region of its higher concentration (or lower solute concentration) to a region of its lower concentration (or higher solute concentration) through a selectively-permeable membrane.

89. In meiosis, each of the four daughter cells has one set of chromosomes. Due to randomness of process of chromosome separation in meiosis, large number of chromosome combinations can form gametes. How many such chromosome combinations in the gametes are possible in case of humans, assuming there is no crossing-over taking place?

- (1)  $2^{22}$
- (2)  $2^{23}$
- (3)  $2^{46}$
- (4)  $2^{34}$

**Answer (2)**

**Sol.** Formula that allows to compute the chromosome combinations, during gametes formation:

$2^n$ , here n = number of different chromosomes

In case of humans,

One set of chromosomes contain = 23 chromosomes

So, the chromosome combinations in the gametes are possible in case of humans =  $2^{23}$

90. Sclerenchyma in plants is an example of simple permanent tissue comprising of two types of cells, sclereids and fibres. Why these cells are functionally important to the plants even after they die?

Choose the correct alternative from the options given below.

- (1) Both are thin walled cells lacking intercellular spaces
- (2) Walls in both the types of cells are thick and cutinized
- (3) Walls in both the cell types are thick and usually lignified.
- (4) Both the cells are used for conducting solutes and providing strength to the plant

**Answer (3)**

**Sol.** Sclerenchyma cells are dead with little or no protoplasm. The wall of these cells are highly thickened due to uniform deposition of lignin (a chemical substance which acts as cement and hardens them).

91. Which one of the following organisms has a cellular respiratory pigment dissolved in plasma and is also a predaceous carnivore and shows matiphagy?

- (1) Scorpion
- (2) Cockroach
- (3) Earthworm
- (4) Sea cucumber

**Answer (1)**

**Sol.** In scorpion, the respiratory pigment is dissolved in plasma and it is also a predaceous carnivore that shows matiphagy, (a process in which an organism feed on its own mother).

92. Lichens are sensitive to certain air pollutants and are often replaced by other plants. From the given options choose the best combination of sensitivity and replacement of lichens.

- (1) Sulphur dioxide and moss
- (2) Sulphur dioxide and algae
- (3) Carbon dioxide and ferns
- (4) Sulphur dioxide and grass

Answer (1)

Sol. Lichens are slow growing dual organisms which are sensitive to air pollutant particularly sulphur dioxide. Lichens are first to invade a bare area as they secrete acids to dissolve rock later these pave way to some very small plants like bryophytes (mosses).

93. A student was performing an experiment to understand the enzyme-substrate reaction. The student measured the formation of coloured product using a colorimeter. The student plotted the graph below which shows the reaction rate versus the substrate concentration.

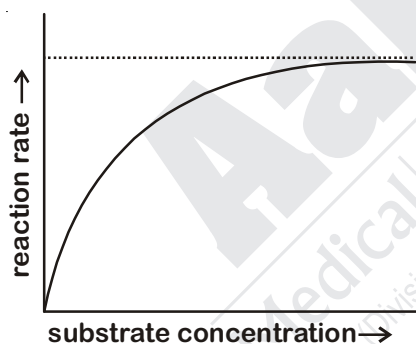

Following interpretations were drawn by the student:

- A. The higher concentration of substrate acts as an enzyme inhibitor.
- B. It is a sigmoidal curve with sharp transition from low to high reaction rates over the increasing substrate concentration.
- C. The curve reaches a plateau and does not further increase with increasing substrate concentrations due to saturation of enzyme with the substrate.

Choose which of the interpretations of the graph are correct.

- (1) A and B
- (2) A and C
- (3) B only
- (4) B and C

Answer (2)

Sol. The given graph interprets that the higher concentration of substrate creates saturation in the enzyme-substrate reaction. So, the curve reaches a plateau and does not increase further, because the higher concentration of substrate acts as an enzyme inhibitor.

94. Glucose is the prime source of energy in our body. However, it is stored in the form of glycogen in the muscle and liver of animals and in the form of starch in plants. As a result, every time a cell requires glucose, it must hydrolyze glycogen which is an energy consuming process. Why does the cell store glycogen instead of glucose in free form?

- (1) Glycogen is more compact and more hydrophilic.
- (2) Storage of glucose in free form will consume more ATP.
- (3) Glucose in the free form creates more osmotic pressure.
- (4) Glucose is highly reactive molecule hence storing in the free form can result in unwanted reactions in the cells.

Answer (3)

Sol. The cell stores glycogen instead of glucose in free form because glycogen do not affect the osmotic pressure of the cell rather than glucose which can disturb the osmotic pressure and will cause cell to lyse.

95. The figure given below is designed to show yeast respiration. In one of the tubes, there is yeast suspension in glucose solution. This solution was boiled before yeast was added to it. Which one of the following is the possible reason for boiling of sugar solution?

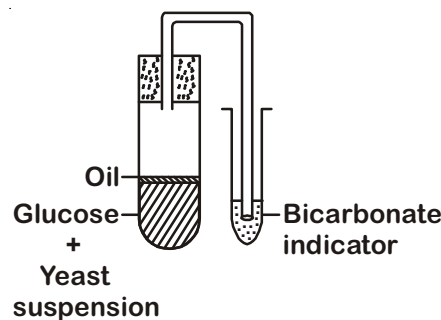

- (1) To ensure aerobic fermentation.
- (2) To provide the initial warmth for the yeast to become active.
- (3) To remove the dissolved oxygen and carbon dioxide from the solution.
- (4) To remove dissolved carbon dioxide and trap the oxygen from the atmosphere.

Answer (3)

**Sol.** On boiling the sugar solution, all types of gases like ( $O_2$ ,  $CO_2$ ) will be removed from the solution. As presence of oxygen and high concentration of carbon dioxide will hinder the process of anaerobic fermentation.

96. A squirrel was eating a fruit on the ground. Suddenly it was attacked by a dog. The squirrel rushed to the tree immediately and saved itself from the dangerous attack. What immediate changes are most likely to have taken place in the body of the squirrel?

- A. Blood flows to the stomach for rapid digestion.
- B. Adrenalin was secreted in the blood by the adrenal glands.
- C. Heart beat becomes faster and pumps more blood so that muscles get more oxygen.
- D. Adrenocorticotrophic hormone is secreted in the blood and blood flows more towards the vital organs.

Select the correct combination of options given below:

- (1) A and B                      (2) A and C
- (3) B and C                    (4) C and D

**Answer (3)**

**Sol.** In this situation, a hormone called adrenaline is released from adrenal glands into the blood which acts on heart and fastens the heart beat, resulting in supply of more oxygen to the muscles and thereby decreases the flow of blood to the digestive system.

97. Stimulus from the environment is detected by the nerve cells. The stimulus acquired is transmitted in the form of electrical impulse. From the options given below choose the correct scheme showing the direction in which the nerve impulse travels. (Arrows shows the direction of impulse flow).

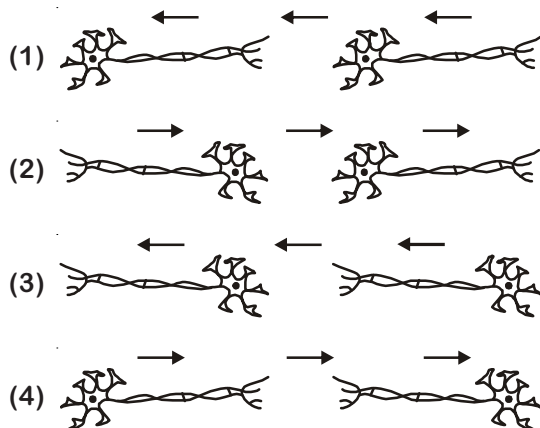

**Answer (3)**

**Sol.** Dendrites or dendrons conduct nerve impulses towards the cell body (cyton). From cyton, the axon conducts the nerve impulse towards the nerve endings and further transmitted to dendrites of another neuron.

98. "Double fertilization" is a complex mechanism of flowering plants that is also unique to angiosperms. Choose the most appropriate statement from the options listed below that explains this phenomenon.

- (1) Fertilization in two flowers of the same plant forming endosperms.
- (2) Two male gametes fertilize two eggs inside the ovule as a result the ovary gives rise to bigger fruits.
- (3) Two fertilizations occur in a flower-one fertilization results in the formation of a diploid zygote and the second fertilization results in the formation of a triploid endosperm.
- (4) Two pollen grains sending two pollen tubes inside the ovary, resulting in the formation of two seeds inside the fruit.

**Answer (3)**

**Sol.** In double fertilization, one male gamete fuses with the egg and results in the formation of a diploid zygote and this process is called fertilization. The other male gamete fuses with the two polar nuclei to form a triploid endosperm. This process is called triple fusion.

99. It is generally observed that malaria is rampant in areas where construction work and/or stagnant water are usually seen. *Plasmodium* species are known to cause malaria. The parasite when injected by the mosquito into the human blood stream goes through specific life cycle stages. Select from below the correct sequence of stages.

- (1) Mosquito (sporozoites) → human liver (merozoites) → human RBC (gametes) → mosquito (zygote-oocyst-sporozoites)
- (2) Mosquito (merozoites) → human RBC (gametes) → human liver (sporozoites) → mosquito (oocyst-zygote-sporozoites)
- (3) Mosquito (merozoites) → human liver (sporozoites) → human RBC (gametes) → mosquito (oocyst-zygote-sporozoites)
- (4) Mosquito (sporozoites) → human liver (sporozoites) → human RBC (merozoites) → mosquito (zygote-oocyst-sporozoites)

**Answer (1)**



**Sol.** When the infected female *Anopheles* bites a human to suck blood, it also injects parasites (sporozoites) with its saliva. Sporozoites reach the liver through blood and divides to form merozoites and are released into the blood. Inside blood corpuscles, these merozoites form the gametocytes. The female mosquito takes up gametocytes with blood meal. Fertilization and development of parasites take place in the mosquito's stomach.

100. A plant with red coloured flowers is crossed with a plant having white flowers. The red and white colour of the flower is controlled by a single gene. Red is dominant over white. The F1 progeny is self-pollinated and the flower colour in F2 is observed.

Given the above information, what is the expected phenotypic ratio of plants with different flower colours?

- (1) All plants with red flowers
- (2) Red : white in the ratio of 3 : 1
- (3) Pink : white in the ratio of 3 : 1
- (4) Red : pink : white in a ratio of 1 : 2 : 1

**Answer (2)**

